

HP: 2 RPM: 1800 AMPS: 2.78 / 5.55 VOLT: 230 / 460 PHASE: 3 Hz: 60
 MOTOR ENCLOSURE: TEXP
 CONTROL TYPE: Starter
 CONTROL PRESS. SET 105 (PSI) CUT IN, 125 (PSI) CUT OUT
 OPTIONS: _____

MODEL NUMBER: K1A-17 TANK SIZE: 17 GAL.
 DISPLACEMENT CFM: 6.2 @ 560 RPM
 CFM-FA: 4.0 @ 125 PSI DISCHARGE
 MAX, WORKING PSI: 125
 SHIPPING CONTAINER:
 LENGTH: _____ WIDTH: _____ HEIGHT: _____

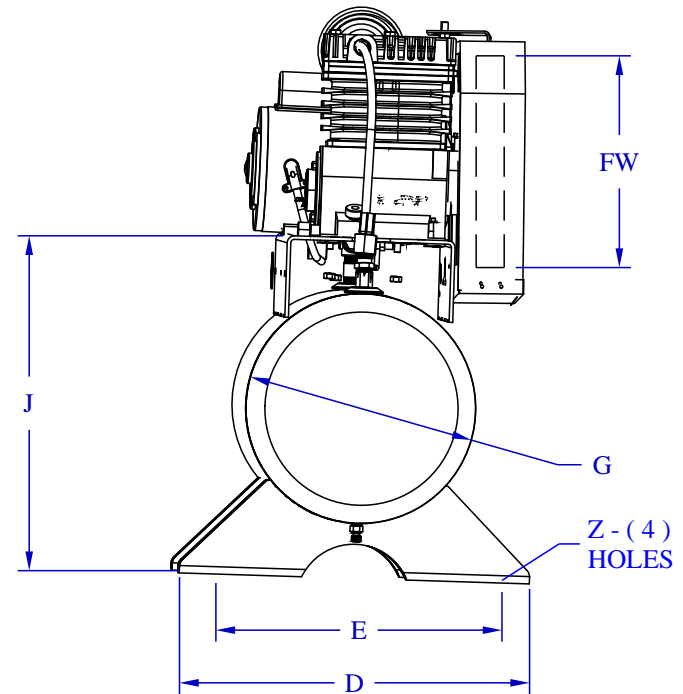
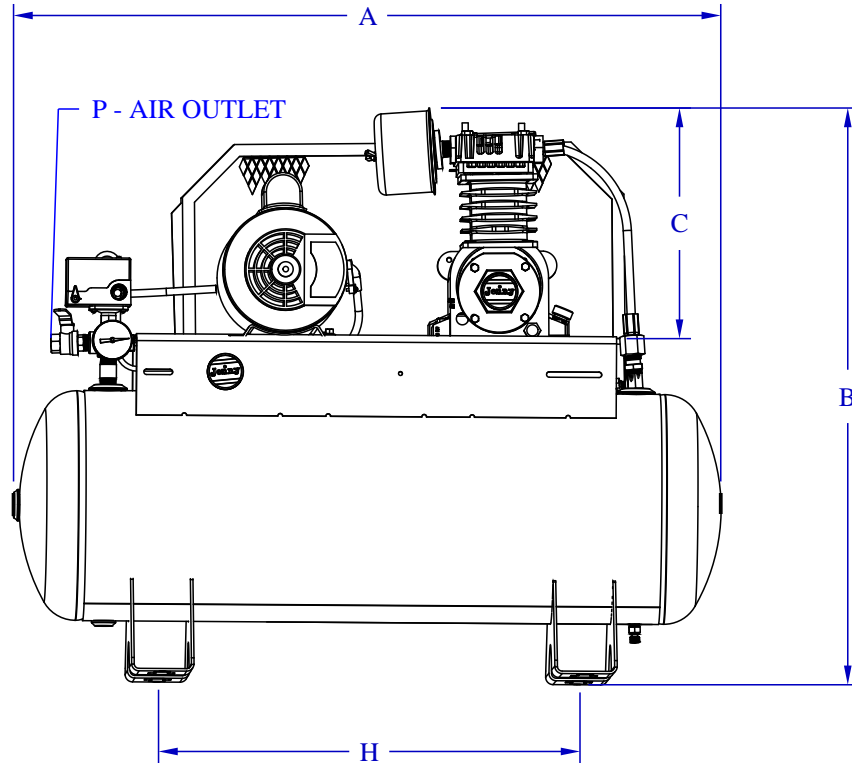

DIMENSIONAL DATA (INCHES)

A	B	C	D	E	G	H	J	FW	P	Z
36 3/4	29 9/16	12 3/16	18 1/4	17 1/4	12	22	17 3/8	10 3/8	1/2	3/8

Jenny
AIR COMPRESSOR

Caron
MEASUREMENT & CONTROLS
780-524-5954
www.caroncontrols.com