

# TOP CUT SAMPLER

TC-200E User Manual

Electric Drive

## CARON MEASUREMENT & CONTROLS

May 2019

Tyler Palinkas

# TABLE OF CONTENTS

<b>1</b>	<b>SAFETY</b> .....	<b>3</b>
1.1	SAFETY PRECAUTIONS .....	3
<b>2</b>	<b>OPTIONAL ACCESSORIES</b> .....	<b>4</b>
2.1	MOUNTING .....	4
2.2	FLOW SIGNAL .....	4
2.2.1	<i>Dry Contact</i> .....	4
2.2.2	<i>Analog Input</i> .....	4
2.3	INSULATED AND HEATED ENCLOSURE.....	4
<b>3</b>	<b>TOP CUT OPERATION</b> .....	<b>5</b>
3.1	SCHEMATIC DRAWINGS .....	6
3.1.1	<i>P&amp;ID Diagram</i> .....	6
3.1.2	<i>Wiring Diagram</i> .....	7
3.2	INSTALLATION .....	8
3.3	STARTUP PROCEDURE.....	9
3.4	CALIBRATION .....	9
3.4.1	<i>Sample Volume</i> .....	9
3.4.2	<i>Safety Shutoff</i> .....	10
3.4.3	<i>Backpressure regulator</i> .....	11
3.5	CONFIGURATION.....	12
3.5.1	<i>Changing the sampler Mode</i> .....	12
3.5.2	<i>Adjusting the Sample Pump Volume</i> .....	13
3.5.3	<i>Adjusting the Stop Pressure</i> .....	14
3.5.4	<i>Setting the Sample Pump Action</i> .....	14
3.5.5	<i>Resetting the Sample Container</i> .....	14
3.6	PREVENTATIVE MAINTENANCE .....	15
<b>4</b>	<b>TROUBLESHOOTING</b> .....	<b>16</b>

## 1 SAFETY

### 1.1 SAFETY PRECAUTIONS

- the sampler enclosure should be vented independently to a safe location and a minimum of 1.5m from any electrical enclosure.

## 2 OPTIONAL ACCESSORIES

### 2.1 MOUNTING

The top cut sampler can be mounted in various configurations. Wall mounting tabs are shipped with the standard sampler package. Optionally available is a universal stand, allowing the sampler to be located on any level surface. Custom built stands are available upon request.

### 2.2 FLOW SIGNAL

For the Top Cut Sampler to accurately sample in proportion to flow, a flow signal input can be supplied to the sampler. In order to use this feature, the optional Standard Input board must be installed. For wiring of the IO board via the auxiliary terminals (A1 through A8) see section 3.1.2.

---

#### 2.2.1 DRY CONTACT

The Top Cut Sampler can also utilize any dry contact to indicate flow such as a relay, pressure switch or flow switch. This input can be configured to sample based on a pulse per volume flow or to take one sample every pulse. Use dry contacts only, do not supply voltage to these terminals.

---

#### 2.2.2 ANALOG INPUT

A 4-20mA signal can be supplied to the sampler to indicate a flowrate condition. The sampler can be configured to adjust its sample frequency based on a flowrate.

### 2.3 INSULATED AND HEATED ENCLOSURE

For outdoor operation the Top Cut Sampler is available with an insulated and heated enclosure. The thermostat controlled heater will maintain above freezing temperatures inside the sampler. The heater requires a 120-240vac power source. Please contact the Sales department for more detailed heater specifications.

### 3 TOP CUT OPERATION

The Top Cut Sampler electronic drive system requires a 24v power supply. See the wiring section of this manual for more detailed information.

The sampler can operate in multiple configurations. Samples can be obtained on a time-based interval continuously or enabled and disabled based on a flowing condition supplied to an input. The sampler can also be operated proportionally based on a volume flow rate or flow total.

The controller samples the process by stroking the sample pump to obtain a 1mL to 3mL sample each stroke. The sample is drawn from the line and forced into the sample container by the sample pump.

In Time based operation, a sample interval will be input into the controller and a sample will be taken every time the interval is reached. If a flowing condition signal is applied, the timer will only run when there is a flowing condition.

In proportional operation, the sampler is configured to sample based on a volume of flow. The controller is set to take a sample at a configured amount of volume. The volume is supplied to the sampler from a pulsed input, or 4-20mA signal.

Time setting should be set to fill the sample container with 7.2L of fluid at the end of the chosen sample period. The controller will keep track of the estimated volume of the container and stop at 7.2L. Once the container is emptied, the controller needs to be reset and will continue sampling. A safety shutoff valve is used to disable the sample pump when the sample cylinder reaches 7.2L. Because the safety shutoff uses weight of the sample container to gauge its contents, it needs to be calibrated to actual sample density (See section 3.4.1).

## 3.1 SCHEMATIC DRAWINGS

### 3.1.1 P&ID DIAGRAM

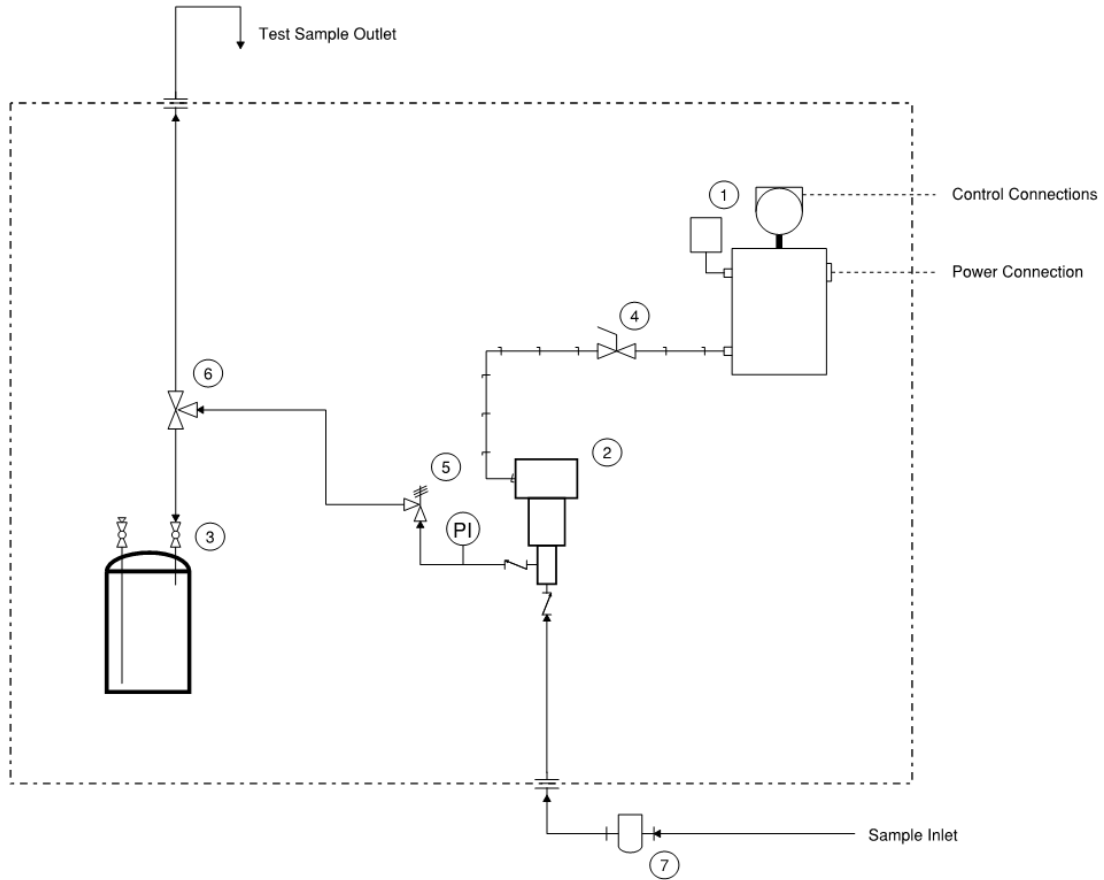

ITEM	DESCRIPTION
1	ELIMINATOR ELECTRONIC CONTROL UNIT
2	SAMPLE PUMP
3	7.2L SAMPLE CONTAINER
4	SAFETY SHUTOFF VALVE. DISABLES SAMPLE PUMP WHEN SAMPLE CONTAINER REACHES A CERTAIN WEIGHT.
5	BACKPRESSURE REGULATING VALVE. PREVENTS SAMPLE FROM FREE FLOWING THROUGH PUMP.
6	SAMPLE DIVERT VALVE. SELECT SAMPLE TO OPERATING OR TEST CONTAINER.
7	SAMPLE INLET FILTER

6

FIGURE 3.1.1

### 3.1.2 WIRING DIAGRAM

Power to the control unit is connected to the 10AWG flying leads on the right side of the main enclosure. Only control connections are made in the ECU (display enclosure). The control unit requires 24VDC and draws a max of 3amps. A 5amp fuse should be used for supply power. See the diagram below for control wiring.

Main Header (Bottom of Board)

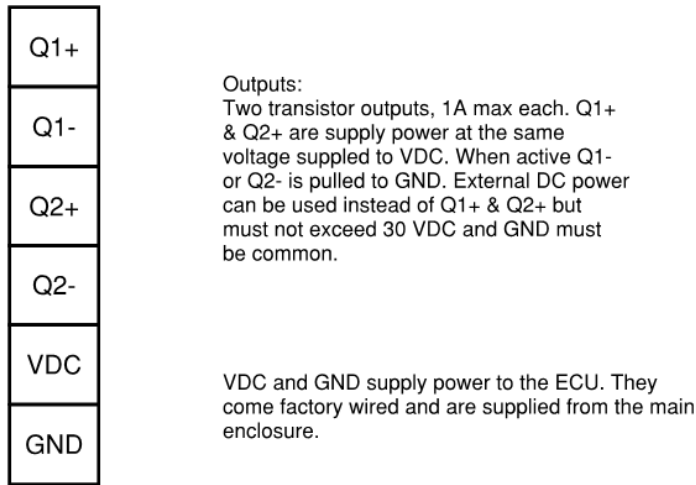

Aux Header, Top of board (Showing Standard Input Board Model IFB-SIN Installed)

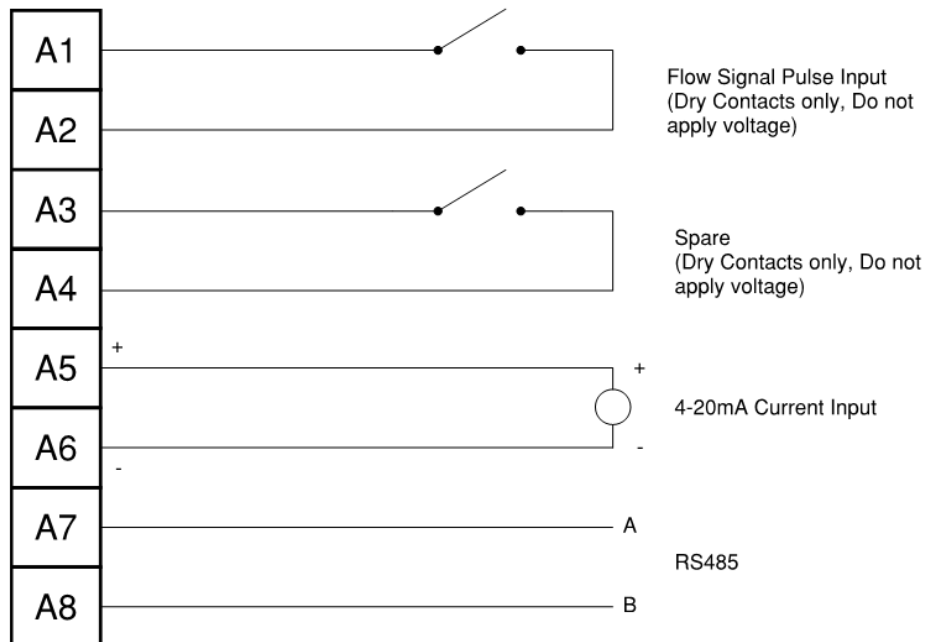
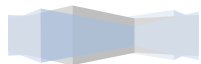

FIGURE 3.1.2



### 3.2 INSTALLATION

Proper installation is integral to reliable and accurate operation of your TopCut Sampler. The following information is meant to assist you in setting up the sampler for optimal operation.

First step is to find an appropriate location for the sample point. It is important to select a sample point where the product will be well mixed. We recommend the use of a static mixer upstream of the sample point for most applications. Various sizes and styles of mixer are available; contact our sales department for mixer and sample quill options. When installing the sample quill, the beveled edge should face upstream, against flow. Ideally the quill should be mounted off the top of the pipe. See figure 3.2.1 below.

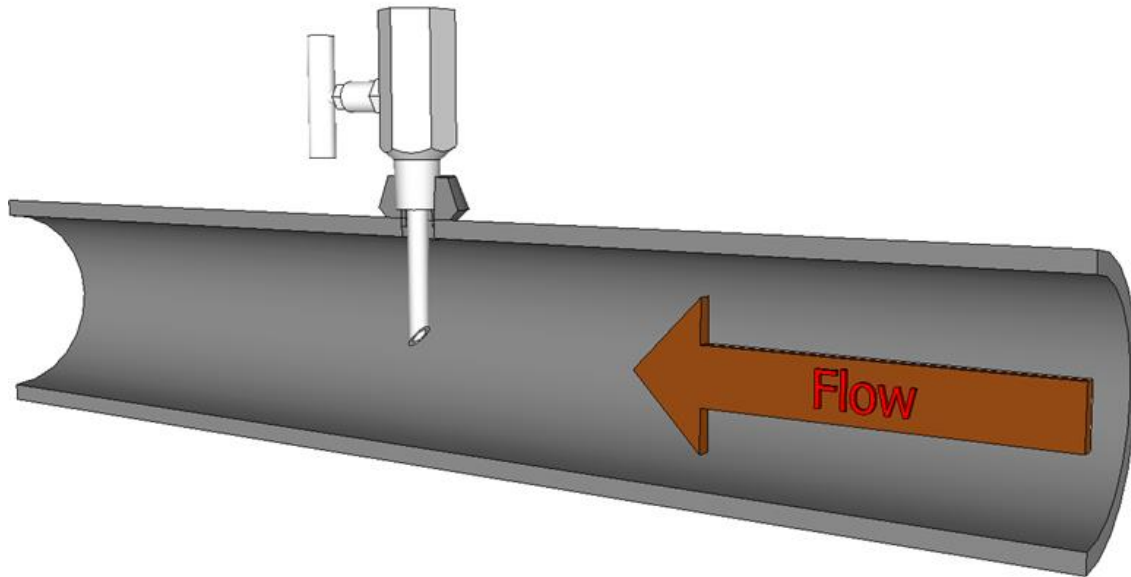

Figure 3.2.1

Another point to consider when selecting a sample point location is the sampler itself. Find a secure mounting location for the sampler as close to the sample point as possible.

Connect the sample probe the fitting on the sampler marked **SAMPLE** using 1/4" or 3/8" tubing.

### 3.3 STARTUP PROCEDURE

The following procedure should be performed prior to first use and whenever anything that could affect the sampler operation is changed. For example, anything that would introduce air to the process upstream of the sample point can cause the sampler to become air locked. Within these instructions the term “buttons” is used to describe both the faceplate buttons and the magnetic switches. Magnetic switches can be used to configure the sampler without removing the enclosure cover.

1. Check and ensure all fittings and connections are tight. Close all valves and set the sample divert valve to the sample container.
2. If not already, turn the sampler off by scrolling to the “Sampler Status” screen and pressing the down button or by pressing the UP and DOWN buttons on any screen. Caution: Do not remove display cover unless atmosphere is known to be non-hazardous.
3. Open the sample point valve.
4. Purge System: To purge system, place a container underneath the pump bleed valve and slowly open ½ to 1 turn. Allow fluid to flow out into the container until a constant air free stream is observed. Proceed to tighten the bleed valve.
5. Carefully remove the cap on the test sample outlet line and place a jug underneath. Slowly move the divert valve to the test outlet position.
6. While on the “Sampler Status” Screen, press the up button once to enter running mode. Press up again, the screen will show “Entering Test i5”. Press up 5 more times to enter test mode. The screen will count down from 5 at each press. Once in test mode the pump will stroke continuously. Note: To exit test mode press the up or down button.
7. Continue to run sampler in test mode until continuous air free samples are observed from the test sample outlet.
8. Verify 1mL per sample. For help on this step see “Sample Volume” calibration in section 3.4.1. Once complete, exit test mode by pressing the up or down button and sampler will revert to stopped status.
9. Install empty sample container and connect quick connect if not already installed.
10. Move divert valve to the sample container position.
11. While on the “Sampler Status” screen, press the up button to put the sampler into running mode. See section 3.5 for detailed configuration of each sampler mode.

### 3.4 CALIBRATION

Before initial use, and periodically there are 3 key points on the sampler that should be calibrated to ensure accurate and reliable operation.

**IMPORTANT:** Before performing a calibration, follow the startup procedure in the next section. The system needs to be purged with fluid for a successful calibration. The startup procedure also includes detailed instructions on starting and stopping the sampler as well as putting the sampler into test mode.

9

#### 3.4.1 SAMPLE VOLUME

The sample pump should accurately take a 1mL sample every stroke (unless otherwise configured). For accurate results, the pump and the sample tubing **MUST** be properly purged of all trapped air. Follow the

procedure in section 3.3 Step 4 for purging unit. **Section 3.3 also describes in detail starting and stopping the sampler which will not be described here.** To calibrate the sample volume, follow these steps:

1. Stop The sampler
2. Remove the cap from the sample test port and place a 100ml graduated cylinder (or similar) underneath the opening.
3. Move the divert valve to send the sample to the test port.
4. Place the sampler into test mode.
5. Fill the container with 10 samples and take sampler out of test mode.
6. the sample should have increased 1mL every stroke, ending at 10mL more than the initial position. If this is not the case, adjust the SAMPLE ADJUST KNOB on the sample pump slightly. Empty the test cylinder and repeat from step 4.

---

#### 3.4.2 SAFETY SHUTOFF

The safety shutoff valve is designed to disable the sample pump when the sample container is full. Improper setup can result in low sample volume or a spill caused by overfill. The valve typically comes preset but should be set to actual process fluid density. Follow these steps to set up the valve.

1. Place the empty container and connect the sample hose to the container. **Important:** Make sure anything that would be on the container or tray during operating conditions is present during calibration. Anything that would affect the weight needs to be considered.
2. open the lid of the container, making sure to leave it hanging somewhere on the container or tray.
3. Gather 7.2L of actual process fluid of the density the sample would see during operation.
4. Make sure the safety shutoff switch is in the ON position.
5. While keeping an eye on the safety shutoff, begin pouring the process fluid into the sample container, slowing down when the sample container gets close to 7.2L.
6. The safety shut off valve should snap to the off position just as the container reaches 7.2L. If this is true, calibration is complete. If it tripped early proceed to step 7, if it did not trip at all, proceed to step 8.
7. With the full 7.2L in the container, lift the tray slightly and reset the safety switch. Loosen the locknut on the spring adjust bolt and back the adjustment nut off loosening the spring until you are able to lower the tray and the SSV does not trip.
8. With the tray fully supported by the spring loosen the locknut on the spring adjust bolt (if you haven't already done so) and begin to tighten the adjustment nut, tightening the spring. Continue slowly tightening the nut, watching the SSV, until it trips. Stop tightening and secure the locking nut. The spring should now be close the 7.2L setting, but calibration is not yet complete.
9. Remove and collect a small portion of the sample from the container and reset the safety shut off.
10. Repeat step 5, then move to step 11
11. If the safety shut off did not snap just as the container reached 7.2L continue to step 12. If it did, calibration is complete
12. Loosen the adjustment locknut and make a small adjustment to the adjustment nut. If the SSV tripped early, tighten the nut. If it did not trip, loosen the nut.
13. Secure the locknut and go back to step 9 and continue.

---

### 3.4.3 BACKPRESSURE REGULATOR

The backpressure regulating valve is designed to prevent free flow of the process fluid through the pump. Normally it is set to the MOP of the process. The pump and tubing should be properly purged (Section 3.3, Step 4) prior to performing this step. **Section 3.3 also describes in detail starting and stopping the sampler which will not be described here.**

*NOTE: This valve should come preset from factory and should not require adjustment under normal conditions. This section also assumes prior knowledge of sampler operation.*

1. Stop the sampler
2. Divert the sample to a test container using the test sample outlet line.
3. loosen locknut on backpressure valve.
4. Place the sampler into Test mode.
5. Adjust backpressure valve in to raise pressure and out to lower. the valve should maintain the desired set point in between pump cycles. During a pump stroke, it should read slightly higher.
6. Remove the sample from test mode.
7. tighten locknut and tag switch.
8. Divert sample back to container and return timer to running mode.

## 3.5 CONFIGURATION

Configuration of the sampler can be done via the display by using the buttons on the face or the Magnetic switches located around the enclosure. The magnetic switches allow configuration without removing the housing cover. The position of each switch is marked on the faceplate. This manual will use the term buttons throughout which describes both the faceplate buttons as well as the magnetic switches.

**CAUTION: DO NOT** remove the housing cover unless the area is known to be non-hazardous.

To access the configuration menu, use left and right to scroll to the “Menu Access” screen. Press up to access and left and right to scroll through the menu options. Once finished, scroll to the “Save & Exit Menu” to save the settings and exit the menu.

---

### 3.5.1 CHANGING THE SAMPLER MODE

To change the operating mode of the sampler, navigate to the “Menu Access” Screen using the Left or Right buttons. Once on the screen press up to access the Menu Screens. The first menu screen is “Sampler Mode”. Use the up and down buttons to change the mode of operation. If the Standard IO Board is installed there are 4 options for sampler mode, otherwise only Continuous Time mode is available.

- **Test:** The sampler will sample every 10 seconds
- **Continuous Time Based:** The sampler will sample every configured number of seconds.
- **Auto Time Based:** The sampler will sample every configured amount on minutes based on the user configured period and flow hours per period.
- **Proportional:** If equipped this mode the sampler will sample based on volume flow rate supplied to a flow signal input and user configured sample periods. See the following sections for detailed configuration.
- **Direct External:** In This mode the sampler will stroke every time a pulse is supplied to the flow signal input.

---

#### 3.5.1.1 CONTINUOUS TIME BASED

A sample will be taken based on a timed interval. The interval can be adjusted in 1 second increments. Pressing the up and down buttons together will enable 10 second adjustments. To adjust the interval, navigate to the “Interval Adj” Screen and use the up and down buttons to adjust the time. Hold down the button to scroll faster.

---

#### 3.5.1.2 PROPORTIONAL (OPTIONAL)

To setup proportional sampling, a flow signal input must be selected. The menu items will change based on your selection of flow signal input. To access all the settings described navigate to the Menu Access screen and press the up button. Once in the menu, user the left and right buttons to scroll through the options and the up and down arrows to adjust the settings.

12

There are two input modes that can be selected. Analog, and Pulse. Based on this selection, there are other settings that need to be configured:

For Analog:

- URV in M3/Day – Adjust the 20mA range value in M3/Day.
- Sample Period – Adjust the period desired to obtain a full sample container.
- Average M3/Period – Adjust the typical expected amount of flow over the sample period.

For Pulse:

- Pulse/M3 – Adjust the amount of volume referenced in each pulse
- Sample Period – Adjust the period desired to obtain a full sample container.
- Average M3/Period – Adjust the typical expected amount of flow over the sample period.

---

### 3.5.1.3 AUTO TIME BASED

In situations where time-based sampling is required, but sampling is required to stop periodically due to non-flowing conditions, automatic time-based sampling can be selected. In this mode, the sampler will only run when a flowing condition is met. The time interval is calculated based on a user input sample period and a typical production hours per day.

To setup auto time-based sampling, the flow signal pulse input must be selected. Closing the pulse input will indicate a flowing condition, opening will stop the sampler. To access all the settings described navigate to the Menu Access screen and press the up button. Once in the menu, use the left and right buttons to scroll through the options and the up and down arrows to adjust the settings.

- Sample Period - Adjust the period desired to obtain a full sample container.
- Production per Day – Set the typical expected production hours per day.

---

### 3.5.1.4 DIRECT EXTERNAL

If the existing control system such as a PLC or RTU is setup to calculate and control the sample interval direct external control can be used. In this Mode a 3 second pulse is applied to the pulse input which triggers the sampler to take a sample. The external system must be configured with a volume/sample that matches the configuration of the sample pump. This is usually 1mL per stroke but can be configured up to 3mL. The control unit will not monitor the product in the container, this must be monitored by the external control system. A counter should be setup to stop the sample signal once the container is full.

---

## 3.5.2 ADJUSTING THE SAMPLE PUMP VOLUME

The sample pump can sample from 1mL to 3mL per stroke. The standard configuration is 1mL. In cases where this needs to be adjusted, the controller will need to be set to match the configuration of the pump.

To Adjust this setting, Use the left and right buttons to navigate to the “Menu Access” screen and press up to enter the menu. Scroll left or right to find the “Pump Volume” screen. Use the up and down buttons to adjust. CAUTION: Improper configuration of the setting can cause the pump to overflow the sample container. Only adjust if you know what you are doing.

---

### 3.5.3 ADJUSTING THE STOP PRESSURE

The Stop pressure is the pressure at which the hydraulic pressure will signal a full stroke. This can also be used to limit the output pressure of the sample pump. This should be set at 10 to 20 percent more than what is require to overcome the setting of the back pressure regulating valve.

---

### 3.5.4 SETTING THE SAMPLE PUMP ACTION

The controller can operate both single acting (spring return) and dual acting sample pumps. The menu screen “Pump Action” is used to select either single or dual acting sample pumps.

In Single Acting mode, when a sample is requested the hydraulic pump will run until the stop pressure is reached then stop. The spring in the sample pump will then push the hydraulic oil back to the reservoir. This is a full sample cycle.

In Dual Acting mode, a 4-way high flow solenoid is required to switch the direction of the oil to the sample pump. It should be wired to the output Q2 on the main board. When a sample is requested the controller will energize Q2 and run the hydraulic pump. Once the stop pressure is reached, the controller will stop the pump, de-energize Q2 and run the pump again until the stop pressure is reached once again. This is a full sample cycle.

---

### 3.5.5 RESETTING THE SAMPLE CONTAINER

When the controller has taken the required number of samples to fill the container, it will stop sampling and display “Sample Full” “Up to Reset i5”. Once the sample container is emptied, cleaned and returned to the sampler, press up 5 times to reset. Once reset, the sample will continue normal operation.

**CAUTION:** If the sampler is reset, but the container not emptied, the sampler may overflow the container.

If the safety shutoff valve has tripped, it will need to be reset when the container is replaced. If there is not the correct amount of sample in the container. The SSV may need calibration.

### 3.6 PREVENTATIVE MAINTENANCE

The following steps should be performed periodically to maintain reliable sampler operation. Over the first few weeks, check more frequently and take the time to develop a maintenance schedule.

1. Check sample filter element (if installed). Remember to properly purge pump after anytime the sample line is opened.
2. Verify sample volume calibration.
3. Check to make sure sample tray moves freely.
4. Check safety shutoff calibration.

Symptom	Possible Cause	Solution
No Sample flow, but pump is stroking	Pump is air locked	Purge sample pump. See section 3.3 Step 4. Check sample filter if installed.
	Sample line or filter is plugged	Clean Sample filter and purge pump.
	A valve is closed	Check Valving
Sample pump is not stroking	No Flow signal	Confirm wiring and a flow signal pulse is being applied to the unit.
	Low supply voltage	Check supply voltage is > 18v
	Sampler is disable	Check to see if sampler is in running mode.
	Failed electronics	Contact Service department for troubleshooting
Too little sample volume	shipping less hours per day then set point	Modify timer setting to less hours per day
	Shipping less hours per day then setting or incorrect flow signal configuration	Review flow signal input configuration settings.
	Sample pump displacement mismatch	Confirm sample size per stroke setting matches configuration of pump.
	Sample volume calibration out	Check sample volume and calibrate if necessary. see section 3.3.1 (check for air locked pump first)
Too much sample volume	Shipping more hours per day then setting or incorrect flow signal configuration	Review flow signal input configuration settings.
	Sample pump displacement mismatch	Confirm sample size per stroke setting matches configuration of pump.

	Sample volume calibration out	Check sample volume and calibrate if necessary. see section 3.4.1
Sample container overfills	Something effecting sample tray from moving freely	Make sure nothing is placed underneath sample tray. Check for smooth tray movement and safety shutoff operation.
	Safety Shutoff valve out of calibration	See section 3.4.2 for calibration

